

FEATURE

- **Installation:** Factory Install - Integral to Fixture
- **Control:** Hold time, High-Low setting, continuous Bi-level dimming, manual/auto - on/off
- **Sensor:** Dusk-to-Dawn Control



SPECIFICATIONS

SENSOR TYPE:	Twist-Lock Photocell
INPUT VOLTAGE:	110-277VAC
ON-OFF LEVELS:	50LUX
POWER CONSUMPTION:	1.2W
SURGE PROTECTION:	40,000Amp
OPERATING TEMP:	-40°F ~ +158°F (-40°C ~ +70°C)
RATED FREQUENCY:	50/60Hz
RATED LOADING:	Tungsten: 1000W Ballast: 1800VA, 5A e-Ballast
TIME DELAY:	10 seconds
RELATIVE HUMIDITY:	99%
DIELECTRIC STRENGTH:	5000Vrms
IP RATING:	IP65
WARRANTY:	5 years

DIMENSIONS

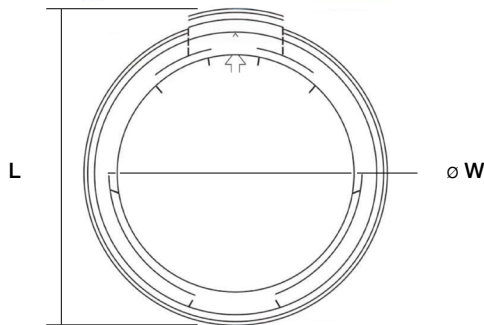

L	W
3.31" (84mm)	ø 3.40" (ø 86mm)

