



LPA SERIES G2 SELECTABLE BACKLIT PANEL

Client:
Project:
Type:
Quantity:

CONSTRUCTION

Low profile extruded aluminum frame, all corners are rounded for safe handling. Multiple wiring entrances on driver enclosure for easy access. The backplate includes integral T-bar clips for installation into T-grid ceilings.

OPTICS

Backlit design provides exceptional lighting distribution. Frosted PMMA lens offers edge to edge illumination without pixilation or bright spots.

ELECTRICAL

Long-life, high-efficacy, micro-power LEDs, illumination for extended service life. Greater than 70% LED lumen maintenance at 100,000 hours (L70>100,000).

Selectable lumen and CCT technology allows easy field-adjustable capability, luminaire ships with maximum output and 4000K CCT setting.

All CCTs are within 3 MacAdam ellipses, 80CRI.

Special made 90CRI LED, consult factory.

Driver operates at 120-277V input, 0-10V dimmable driver, dim-to-off voltage threshold of optional 12V AUX integrated driver ranges from 0.1V to 0.5V.

MOUNTING

Designed to accommodate lay-in ceilings, Slot T, and T-bar suspension system for 5/8" and 3/8" width. Built-in earthquake clips come standard.

Surface/cable mount applications, use surface/cable kit accessories.

Plaster or sheetrock installations, select flange kit.

Hard ceiling application, select hard ceiling kit.

SENSORS (OPTIONAL)

SENSOR-BLE-7 Integral Microwave Bluetooth Wireless Motion/on/off/dimming/ photosensing.

SENSOR-ANT-7 Integral Microwave Motion/on/off/dimming/photosensing.

CONTROL-LVFA AVI-ON Bluetooth Mesh Controller.

STANDARD FINISH

90% minimum average reflective white polyester powder coat bonded to phosphate-free, multi-stage pretreated metal. All parts painted after fabrication to facilitate installation, increase efficiency, and inhibit corrosion.

CUSTOM FINISH

AkzoNobel Interpon 600 Series anti-microbial White / Clear coating for healthcare application.

CERTIFICATION

Meets Buy America Act requirements.

IC Rated, suitable for Damp location.

All luminaires are built to UL1598 standards and bear appropriate cULus labels.

For Emergency application, equipment with UL924 certified battery packs.

DLC® Standard (DesignLights Consortium Listed)

WARRANTY

5 year warranty, see Limited Warranty for additional information.



SHIPPING DATA

Product	Measurement	Weight
LPA-G2-1 (4-pack)	49"L x 13"W x 6"H	23 lb
LPA-G2-2 (4-pack)	26"L x 26"W x 6"H	20 lb
LPA-G2-4 (4-pack)	49"L x 26"W x 6"H	38 lb



LPA SERIES G2 SELECTABLE BACKLIT PANEL

ORDER INFORMATION	EXAMPLE: LPA G2 2 BACKLIT
-------------------	---------------------------

Fixture	Series	Model	Finish	Input
	LPA-G2			
Mounting				
Accessories				
Options				

A	SERIES	
	LPA-G2	Selectable Lumen and CCT Panel, Generation 2

B	MODEL				
	Code	Size	Power	CCT	lm/W (avg.)
	1-BACKLIT	1x4	20W / 25W / 30W / 35W / 40W	3000K / 3500K / 4000K / 5000K / 6500K	110lm/W
	2-BACKLIT	2x2	20W / 25W / 30W / 35W / 40W	3000K / 3500K / 4000K / 5000K / 6500K	110lm/W
	4-BACKLIT	2x4	25W / 30W / 35W / 40W / 50W	3000K / 3500K / 4000K / 5000K / 6500K	110lm/W

C	FINISH	
	WH	White
	AMP	Antimicrobial White Finish, AkzoNobel Interpon 600 Series Anti-Microbial White / Clear coating for healthcare application

D	INPUT			
	blank	120-277V, 0-10V Dimming w/12V AUX Output	MD	120-347V, 0-10V Dimming w/12V AUX Output

E	MOUNTING	
	blank	Standard lay-in
	MOUNT-LP-14-FGK	1x4 Flange Kit (Plaster, Sheetrock or Drywall)
	MOUNT-LP-22-FGK	2x2 Flange Kit (Plaster, Sheetrock or Drywall)
	MOUNT-LP-24-FGK	2x4 Flange Kit (Plaster, Sheetrock or Drywall)
	MOUNT-LP-14-SMK	1x4 Surface Mount Kit for LPA-1
	MOUNT-LP-22-SMK	2x2 Surface Mount Kit for LPA backlit
	MOUNT-LP-24-SMK	2x4 Surface Mount Kit for LPA backlit
	MOUNT-LP-PMK	Aircraft Cable Pendant Mount

F	ACCESSORIES/OPTIONS	
	AIA	Assembled in America, compliant with BAA (COTS)
	EMB-H08170*	High Voltage Output Smart Emergency Battery 8W 100-347VAC Input 170VDC Output
	EMB-H18170*	High Voltage Output Smart Emergency Battery 18W 100-347VAC Input 170VDC Output
	GTD-ESRLUD**	Emergency Battery Generator Transfer Device 120-277 VAC Input
	SENSOR-BLE-7*	Integral Microwave Bluetooth Wireless Bi-Level Motion Sensor (ALS Control Mobile App)
	SENSOR-ANT-7*	Integral Microwave Bi-Level Motion Sensor
	CONTROL-LVFA*	AVI-ON Bluetooth Mesh Control System
	REMOTE-RC100	Handheld Remote Commissioning Tool for SENSOR-ANT (1 per job)
	-C	6-Foot Flex
	90CRI	90CRI (Special made, consult factory)

*see page 5 for sensor and emb spec
 **see page 8-9 for GTD spec

LPA SERIES G2 SELECTABLE BACKLIT PANEL

DIMENSIONS

Model	L	W	D
LPA-G2-1	47.80" (1213mm)	11.90" (301mm)	1.50" (38mm)
LPA-G2-2	23.70" (603mm)	23.70" (603mm)	1.50" (38mm)
LPA-G2-4	47.80" (1213mm)	23.70" (603mm)	1.50" (38mm)

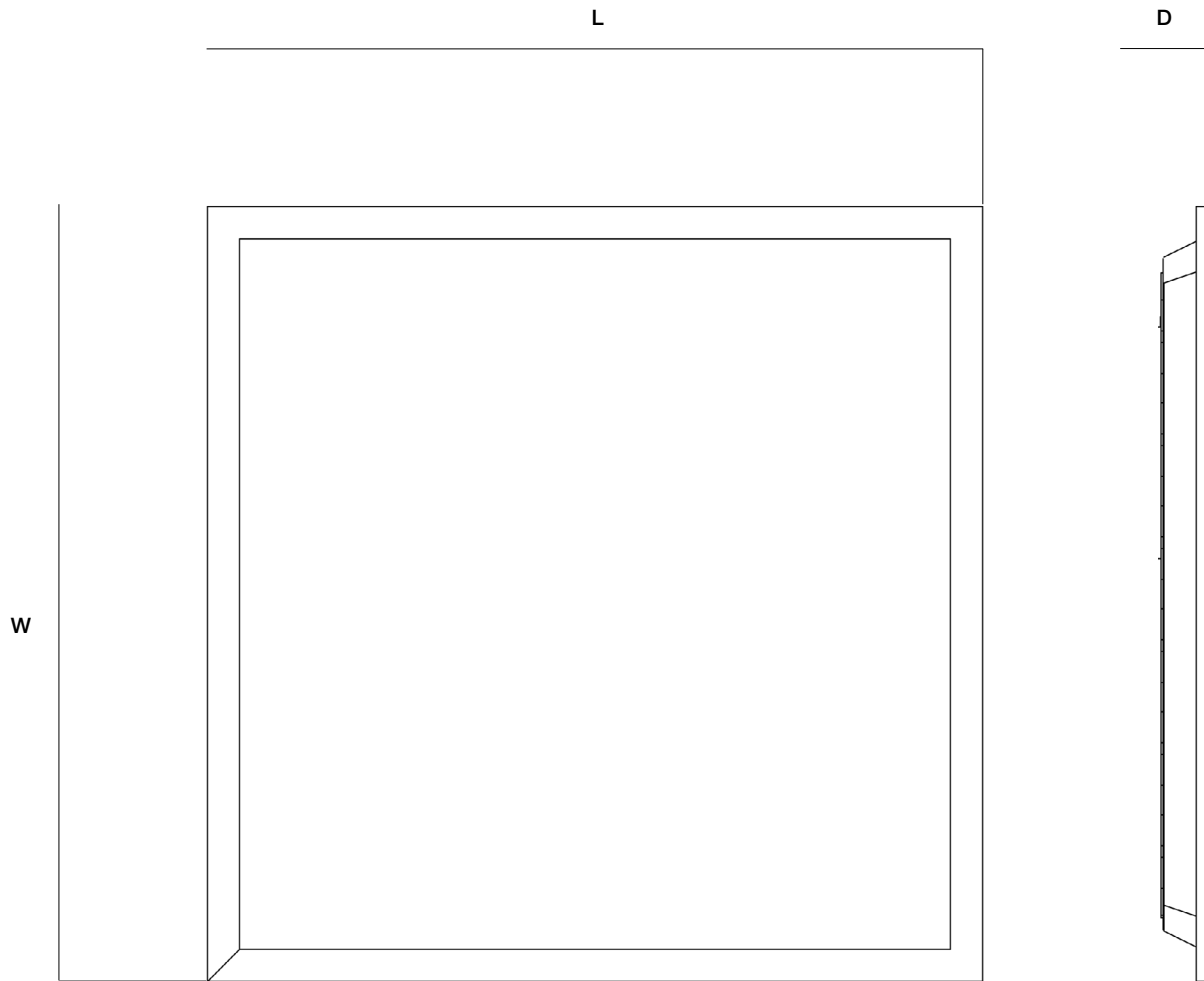

LPA SERIES G2 SELECTABLE BACKLIT PANEL

PERFORMANCE DATA - LPA-G2

SYSTEM WATTS	SIZE	VOLTAGE	LUMEN	LPW	QTY ON PALLET
20W	LPA-G2-1-BACKLIT LPA-G2-2-BACKLIT	120-277V	2200	110	LPA-G2-1-BACKLIT - 120 pcs LPA-G2-2-BACKLIT - 144 pcs
25W	LPA-G2-1-BACKLIT LPA-G2-2-BACKLIT LPA-G2-4-BACKLIT	120-277V	2775	110	LPA-G2-1-BACKLIT - 120 pcs LPA-G2-2-BACKLIT - 144 pcs LPA-G2-4-BACKLIT - 72 pcs
30W	LPA-G2-1-BACKLIT LPA-G2-2-BACKLIT LPA-G2-4-BACKLIT	120-277V	3360	110	LPA-G2-1-BACKLIT - 120 pcs LPA-G2-2-BACKLIT - 144 pcs LPA-G2-4-BACKLIT - 72 pcs
35W	LPA-G2-1-BACKLIT LPA-G2-2-BACKLIT LPA-G2-4-BACKLIT	120-277V	3850	110	LPA-G2-1-BACKLIT - 120 pcs LPA-G2-2-BACKLIT - 144 pcs LPA-G2-4-BACKLIT - 72 pcs
40W	LPA-G2-1-BACKLIT LPA-G2-2-BACKLIT LPA-G2-4-BACKLIT	120-277V	4440	111	LPA-G2-1-BACKLIT - 120 pcs LPA-G2-2-BACKLIT - 144 pcs LPA-G2-4-BACKLIT - 72 pcs
50W	LPA-G2-4-BACKLIT	120-277V	5600	112	LPA-G2-4-BACKLIT - 72 pcs

DLC CODE

Part Number	DLC Product ID	DLC Class
LPA-G2-1-BACKLIT (1x4)	S-EKCAUX	Standard
LPA-G2-2-BACKLIT (2x2)	S-JQ6VLX	Standard
LPA-G2-4-BACKLIT (2x4)	S-V8JOA2	Standard

LPA SERIES G2 SELECTABLE BACKLIT PANEL

SENSOR SPEC

Model	Type	Mounting	Coverage	Input	Function	Programmable
SENSOR-BLE-7 (see page 8 for detail)	Microwave	up to 13FT	17FT radius	12V DC	Bluetooth Mesh On/Off/Dimming Motion Daylight Sensing	ALS Control Bluetooth Mobile App
SENSOR-ANT-7	Microwave	up to 12FT	17FT radius	10V DC	On/Off/Dimming Motion Daylight Sensing	REMOTE-RC100
CONTROL-LVFA (see page 6 for detail)	Fixture Controller	-	-	12V DC	Bluetooth Mesh On/Off/Dimming Scheduling	AVI-ON Bluetooth Mobile App



SENSOR-BLE-7
 SENSOR-ANT-7



CONTROL-LVFA

EMB SPEC

Model	Battery Capacity	Input	Output	Output Power	Operating Temp	Installation
EMB-H08170	90mins	100-347VAC	170VDC	8W	0°C ~ 50°C 32°F ~ 122°F	Factory or Field Install
EMB-H18170	90mins	100-347VAC	170VDC	18W	0°C ~ 50°C 32°F ~ 122°F	Factory or Field Install

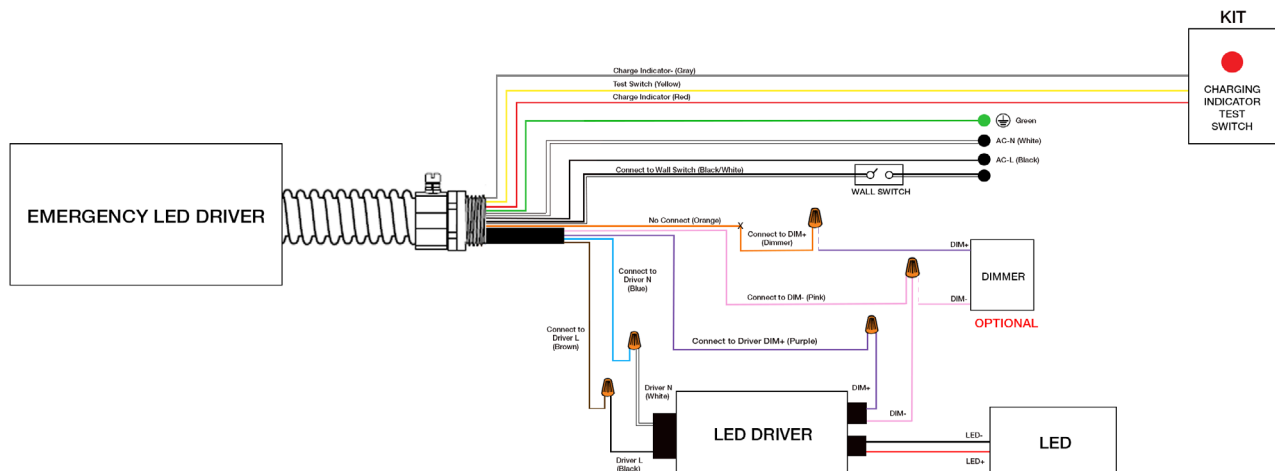

LPA SERIES G2 SELECTABLE BACKLIT PANEL

CONTROL-LVFA SPEC

Status LEDs & Config Button

Quick and easy validation of wiring and network

Direct Connect™ Sensor Port

Simple and cost-effective addition to Avi-on sensors

Terminal Blocks & Mounting Tabs

Faster, easier and lower cost installation eliminating connectors

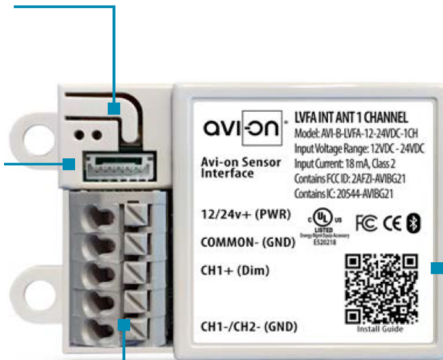

Internal Antenna

Improved performance and eliminates risk of accidentally cutting a hanging wire

SPECIFICATIONS

INPUT VOLTAGE: 12-24VDC
CURRENT: 15mA without a Sensor
 19mA with a DC PIR Sensor
 48mA with a DC Microwave Sensor
0-10V DIMMING: 12-24VDC
SIZE: 2.30in x 1.43in x 0.75in
 (58.2mm x 36.4mm x 19mm)
MOUNTING: Removable mounting tabs
WEIGHT: 0.45 oz (16g)
OPERATING TEMP: -22°F to +158°F (-30°C to + 70°C)

RADIO FREQUENCY: 2.4GHz
WIRELESS STANDARD: BLE 4.2 with Mesh
POINT TO POINT RANGE*: 80ft with obstructions
 350ft unobstructed
SECURITY: AES 128-bit encryption for device to device communication
 AES 256-bit encryption for device to cloud communication
WARRANTY: 5 years; 10 years optional
REGULATORY: FCC: 2AFZI-AVI1010 B
 IC: 20544-AVI1010 B
 BQB: D031801, DID: 86303
 UL 916, 2043 (Plenum Rated)

*When communicating through the mesh, range is essentially unlimited (5000ft+)

WIRING DIAGRAM

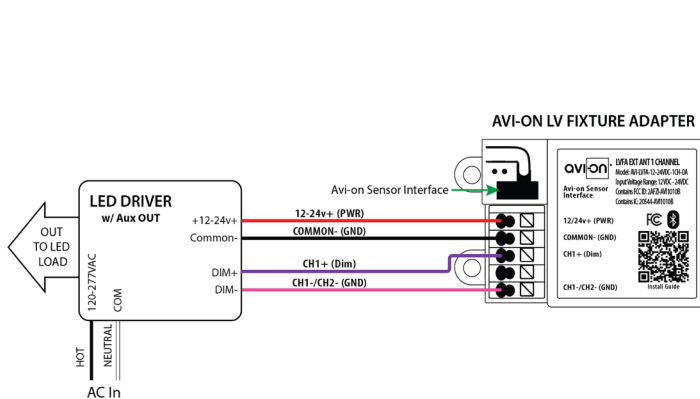

Fixture adapter powered by LED driver auxiliary output

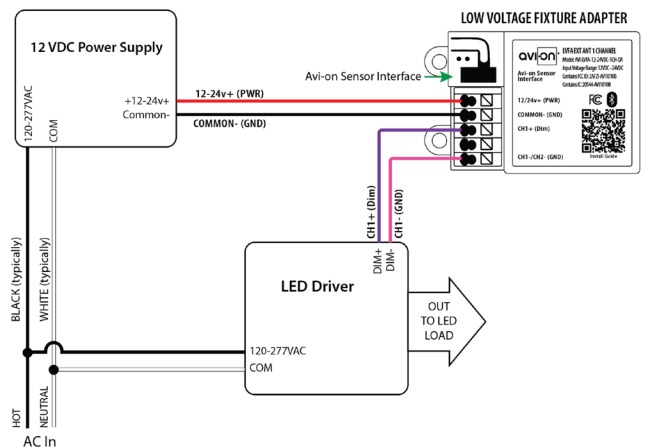

Fixture adapter connected to LED driver and using power supply

FEATURE

- **Installation:** Factory Install - Integral to Fixture
- **Commissioning:** Wirelessly through ALS Control Mobile App (iOS / Android)
- **Certification:** DLC 5.1 Networked Lighting Control System
- **Control:** Hold time, High-Low setting, continuous Bi-level dimming, Code-compliant manual-on or auto-off capability
- **Sensor:** Motion (Occupancy/Vacancy/Manual)
- **Room and Zone Control:** Zoning and Grouping control, Scheduling



SPECIFICATIONS

SENSOR TYPE: Microwave
WIRELESS STANDARDS: Bluetooth SIG Mesh
INPUT VOLTAGE: 10-14VDC, >50mA
CONTROL OUTPUT: 0-10V
OPERATING TEMP: -40°F ~ +158°F (-40°C ~ +70°C)

COMMISSIONING RANGE: 50FT
BLUETOOTH RANGE: Integral antenna up to 164FT
DETECTION ANGLE: 360°
MOUNTING HEIGHT: Up to 13FT
WARRANTY: 5 years
IP RATING: IP20

DIMENSIONS

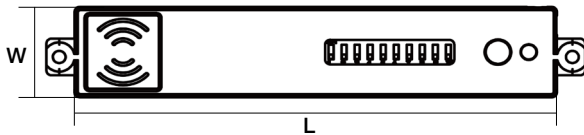

L	W
3.70" (94mm)	0.73" (18.5mm)

COVERAGE PATTERNS

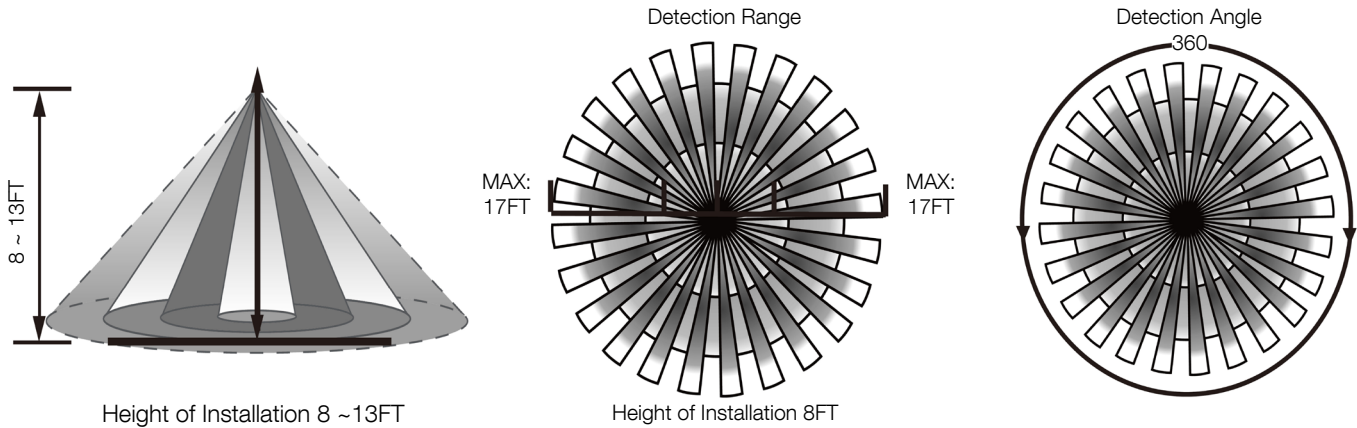

CONSTRUCTION

Yellow metal casing. Integrates with dry contact systems to provide lighting during power outages. Features a slim enclosure, allowing for seamlessly integrating into existing building infrastructure. Designed for commercial and industrial applications that require an emergency load to be switched on during a loss of normal power.

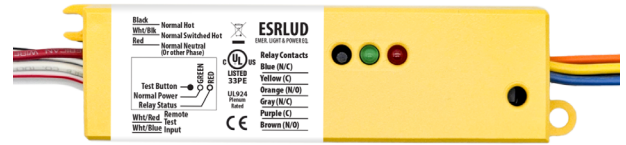

SPECIFICATIONS

COIL CURRENT:	Normal Power = 6mA MAX
COIL VOLTAGE INPUT:	120-277V AC (50/60 Hz)
EXPECTED RELAY LIFE:	10 Million Cycles Min Mechanical
RELAY CONTACT RATINGS:	10 Amp Resistive @ 30 V DC 10 Amp General Use @ 277 V AC
OPERATING TEMP:	-30°F ~ +140°F (-34°C ~ +60°C)
OPERATE TIME:	18ms
HUMIDITY RANGE:	5-95% (Noncondensing)
LED:	Green = Normal Power Red = Relay Status
DIMENSIONS:	1.40"H x 5.63"W x 1.00"D
WIRES:	16", 600V Rated
OVERRIDE (TEST SWITCH):	No
APPROVALS:	UL924, C-UL, CE, ROHS
NOTES:	Device Draws no Current From Emergency Source

TESTING

- INITIAL TEST FOR CORRECT WIRING:**
- a. Green LED (Normal Power) should be ON
 - b. Red LED (Relay Status) should be ON
 - c. Load should be OFF
 - d. Relay Contact (N/O) should be CLOSED
- LOCAL TEST BUTTON:**
1. Turn Switched Circuit OFF. Load be OFF.
 2. Press and Hold "Local Test Button"
 3. Load should Turn ON
 4. Release "Local Test Button" and Emergency Light should Turn OFF.
- WALL SWITCH:**
1. Turn ON Wall Switch If not already ON
 2. Load should Turn ON
 3. Turn Wall Switch OFF
 4. Load will Turn OFF

TROUBLESHOOTING

CONDITION	ACTION
Green LED is OFF	<ul style="list-style-type: none"> • Check Normal Power Input Wiring (Black and Red Wires) and Voltage.
Red LED is OFF but Load is OFF	<ul style="list-style-type: none"> • Check Bulbs and Ballast. • Check Load Wiring (Blue Wire and Load's Neutral). • Replace Unit. (Assuming N/C Contact is Used).
Load is ON but Red LED is ON	<ul style="list-style-type: none"> • Replace Unit. (Assuming N/C Contact is Used).
Red LED does not Turn OFF and Load does not Turn ON when being tested	<ul style="list-style-type: none"> • Check Bulbs and Ballast. • Check Wiring Connections if Using a Remote Test Option. • Press Local Test Button on the Unit. • Replace Unit.
Red LED will not Turn ON and Load will not Turn OFF	<ul style="list-style-type: none"> • Verify Status of Normal Power Input. • Open Wall Switch Input. • Verify That No Test Inputs are Stuck Closed.



GTD-ESRLUD Generator Transfer Device

WIRING DIAGRAM

USING EMERGENCY LIGHTING AS NORMAL LIGHTING

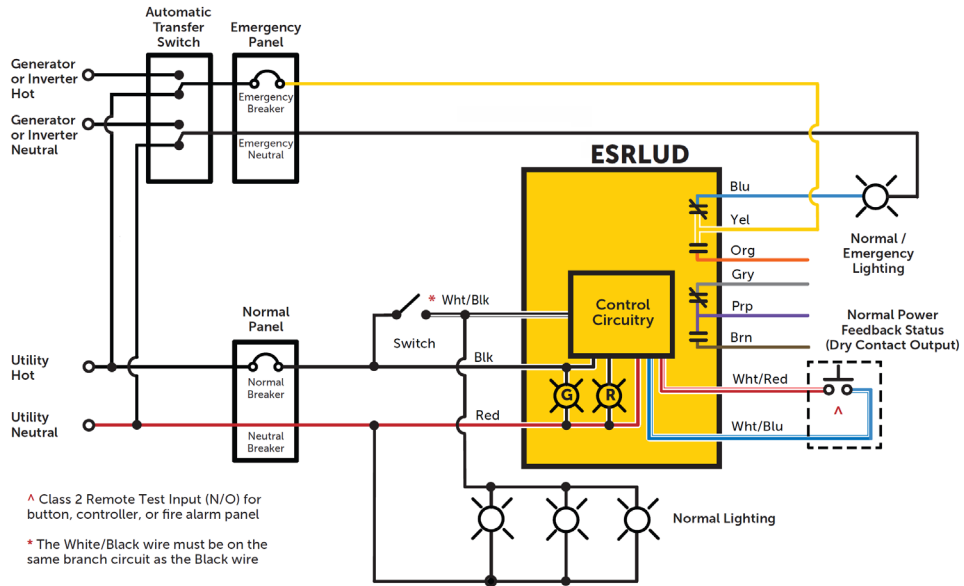

OVERRIDING A 0-10V DIMMER

